

Influence of potential on the friction and wear of mild steel in a model aqueous lubricant

N. P. BRANDON*, N. BONANOS, P. O. FOGARTY, M. N. MAHMOOD, A. J. MOORE, R. J. K. WOOD

BP Research Centre, Sunbury on Thames, Middlesex, TW16 7LN, UK

Received 8 October 1992

An electrochemical cell has been designed, based on a Cameron–Plint friction machine, which enables measurement of friction and wear under conditions of controlled potential. For mild steel in a pH 9 aqueous solution of sodium octanoate, varying the potential of the steel over the range -1 to $+1$ V vs SHE produced three distinct friction-wear regimes: high friction/low wear, low friction/high wear, and low friction/low wear. These regimes were ascribed to potential dependent changes in the coverage and stability of a lubricating octanoate film on the surface of the steel. Increasing the contact stress amplified the effect of potential on wear, and confirmed that the surface film retained its lubricity at contact stresses capable of causing plastic deformation of the steel.

1. Introduction

The potential at a metal–aqueous lubricant interface is important because it determines a number of surface properties, any one of which may be expected to influence friction and wear in a rubbing system. These are: (i) the oxidation state of the metal surface, namely, the chemical composition and thickness of the oxide film; (ii) the surface charge at the metal/solution interface; and (iii) the adsorption of species from the lubricant.

A number of workers have carried out studies of dynamic friction and wear under conditions of controlled potential. Staicopoulos [1] constructed a revolving-cup apparatus to measure the dynamic coefficient of friction of stainless steel and copper against glass as a function of both potential and solution composition. Friction was shown to be a function of potential, and reached a maximum at the potential of zero charge of the metal. Dubois and Lacaze *et al.* [2–4] showed that the appearance of oxides, polymers or other adsorbed species could be detected by measurement of the coefficient of friction of metals such as gold or platinum. Brigham [5] modified a four ball apparatus to allow potential control, and observed maximum friction between type 302 stainless steel balls in 0.3 M sodium sulphate plus 0.05 M sodium chloride at a potential around -200 mV vs S.H.E. Tests have been carried out into the corrosive wear of cast iron in sulphuric acid [6], nickel in sodium perchlorate [7], die steel in sodium sulphate [8], and stainless steel in sea water [9] under potentiostatically controlled conditions. In all cases, corrosion was shown to make a large contribution to the total wear. Lizandier *et al.* have used electrochemical measurements to establish the porosity of ceramic coatings on steel under rubbing

conditions [10], and Kelsall *et al.* [11], and Zhu *et al.* [12] have studied the potential dependence of friction for metal oxides in aqueous solutions.

The aim of this work was to examine the influence of potential on the friction and wear of mild steel in an aqueous lubricant containing octanoic acid neutralized with sodium hydroxide. Aqueous lubricants find application as metal working and hydraulic fluids, and often contain a fatty acid to impart some lubricity and corrosion resistance. Previous work using a tilting electrochemical cell [13] has demonstrated that the static coefficient of friction between iron and mild steel in such a model lubricant could be halved by changing the potential from -400 to $+300$ mV vs S.H.E. This was attributed to electrostatic interactions between the electrode and negatively charged octanoate species.

For the present work, a Cameron–Plint high frequency friction machine was modified to allow potential control of the rubbing surfaces. This enabled measurement of the dynamic coefficient of friction at a fixed load, under conditions of controlled potential, and allowed wear to be determined by examination of the rubbing surfaces. This paper considers the effect of potential, applied load, contact geometry and metallurgy (mild steel on mild steel and high speed steel on mild steel) on friction and wear.

2. Experimental details

2.1 Procedure

In the Cameron–Plint high frequency friction machine a pin is reciprocated against a stationary plate under a fixed load of 10 to 250 N. The stroke length can be

* Present address: Dept 4290, Rolls Royce Applied Science Laboratory, PO Box 31, Derby DE2 8BJ, UK.

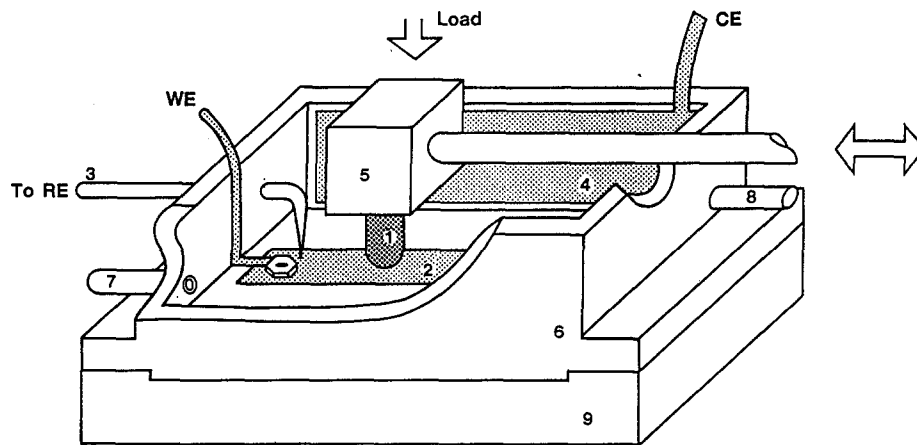

Fig. 1. Electrochemical cell used for friction and wear tests. (1) Mild steel wear pin, (2) mild steel wear plate (working electrode), (3) Luggin capillary to reference electrode, (4) platinum counter electrode, (5) reciprocating head, (6) PVDF sump containing aqueous lubricant, (7) lubricant in, (8) lubricant out, (9) force transducers set in base.

varied from 2.3 to 15 mm, and the frequency of reciprocation from 0.1 to 50 Hz. A piezoelectric transducer measures the instantaneous friction force, which is converted into a mean value and monitored, giving the coefficient of friction.

An electrochemical cell (Fig 1) was designed to fit the Cameron-Plint machine. The cell comprised a PVDF sump with recessed base to accept the wear plate. This plate functioned as the working electrode, and its potential was controlled with respect to a saturated calomel reference electrode located in a separate compartment which was connected to the cell via a Luggin capillary. Two platinum counter electrodes were fixed to the sides of the sump. The aqueous lubricant, which also functioned as the electrolyte, flowed through the cell at a rate of 5 ml min⁻¹. The plate potential was controlled via a Wenking PGS81 potentiostat. The voltage and current outputs of this instrument, together with the friction data from the Cameron-Plint machine, were logged. Each run lasted for one hour, with the friction coefficient being taken as the average over that hour.

The wear plates were lapped to a constant finish of

0.045 μm Ra using diamond paste, and ultrasonically cleaned in white spirit. The wear pins were ground to a radii of 25 or 50 mm. Prior to use pins and plates were degreased by refluxing in cyclohexane, and were kept under dry nitrogen. After use, they were gently wiped and stored in a dry environment. The combination of two pin radii with different applied loads allowed the contact stress to be varied (see Section 2.2). The pins were fabricated from the same mild steel as the plate (EN 24), other than one series of tests carried out using high speed steel wear pins to simulate the metallurgy encountered in metal working applications.

Pin scars were examined by optical microscopy and the mean scar diameter was used to estimate the volume of material removed, based on a spherical pin geometry. Plate scars were similarly examined and measured by a surface profilometer to determine the mode of wear and the plate scar volume, the latter being obtained from the integrated transverse scar profile and the scar length. The pin and plate wear volumes were then converted to specific wear rates expressed in m³ (Nm)⁻¹.

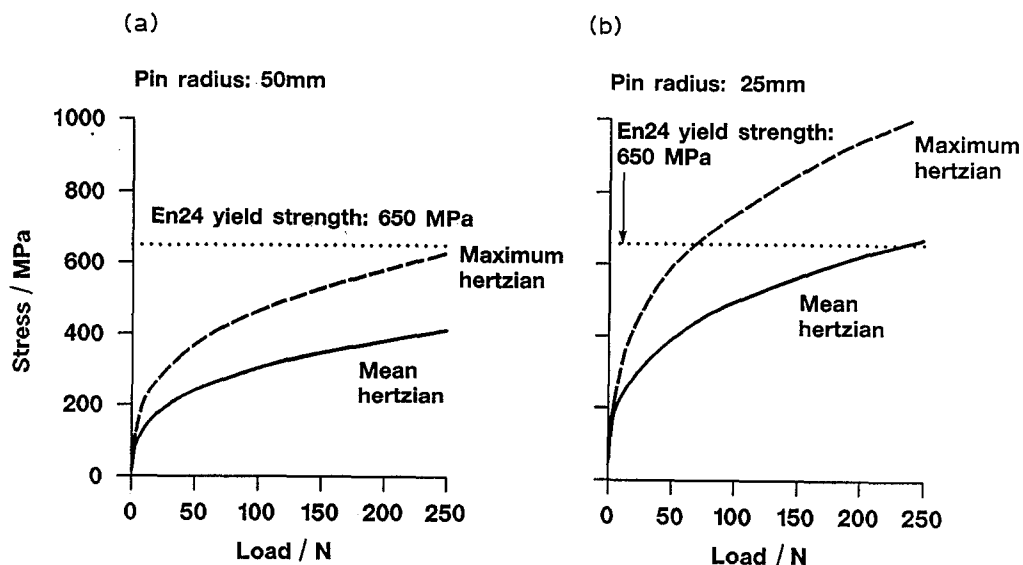

Fig. 2. Calculated Hertzian contact stresses for 25 and 50 mm radii wear pins.

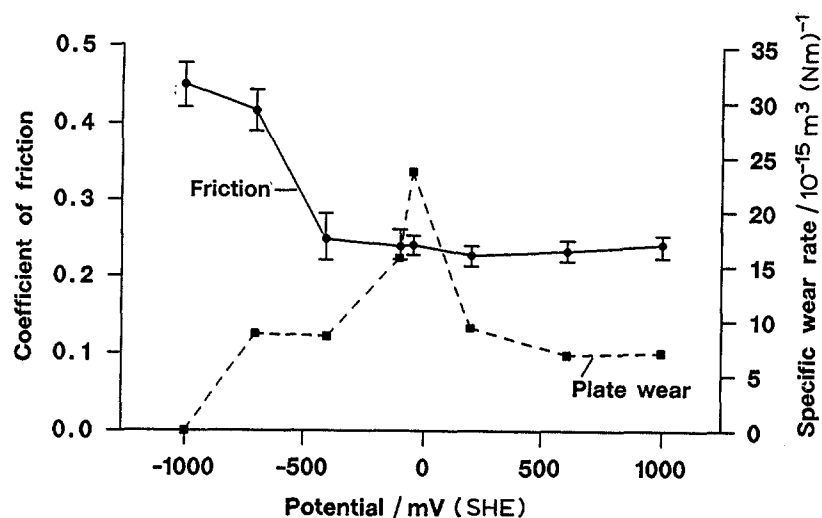

Fig. 3. Potential dependence of friction and wear for 50 mm mild steel pins on mild steel plates at a load of 10 N in a pH 9.2 solution of 1 wt % sodium octanoate.

A solution of 1 wt % octanoic acid in deionised water was made up to pH = 9.2 by the addition of NaOH, and circulated through the cell at 5 ml min^{-1} . Most runs were carried out at 8 or 9 discrete potentials in the range -1000 to $+1000 \text{ mV}$ on the standard hydrogen scale. As well as varying the potential at constant load, the load was also varied at three potentials (-1000 mV , $+600 \text{ mV}$ and rest potential).

2.2 Control of the contact stress

The pin radius (25 and 50 mm) and applied load (10 to 150 N) were selected to give contact regimes ranging from elastic through to plastic. Maximum and mean Hertzian contact stresses were calculated for typical loads varying from 0 to 250 N (Fig. 2). On these curves is superimposed the yield stress of the EN 24 mild steel. The intersection of the yield stress with the maximum Hertzian stress determines the onset of plastic deformation beneath the centre of the area of contact. The intersection of the yield stress with the mean Hertzian contact stress defines the load at which more severe plastic deformation is expected. From Fig. 2 it is apparent that with pins of either radius, the contact was safely within the elastic regime for a 10 N load but that, for 25 mm radius pins, some plastic deformation would be expected to occur when loads of over 80 N were used.

3. Results and discussion

Figure 3 shows a plot of both the dynamic coefficient of friction (μ) and the specific wear rate of the plate for a pH 9 solution of sodium octanoate at eight discrete potentials. Friction fell from a value of 0.45 at -1000 mV to 0.25 at -400 mV vs SHE, remaining low at more anodic potentials. This effect is similar to that observed when measuring the static coefficient of friction of iron [13]. By contrast, the plate wear exhibited a large peak around the rest potential (-60 mV vs SHE). On either side of this peak, plate

wear remained roughly constant, except for the -1000 mV point, where it was effectively zero.

The dominant wear processes for each potential are revealed by reference to the Talysurf profiles (Fig. 4). These show a trend from adhesive wear at cathodic

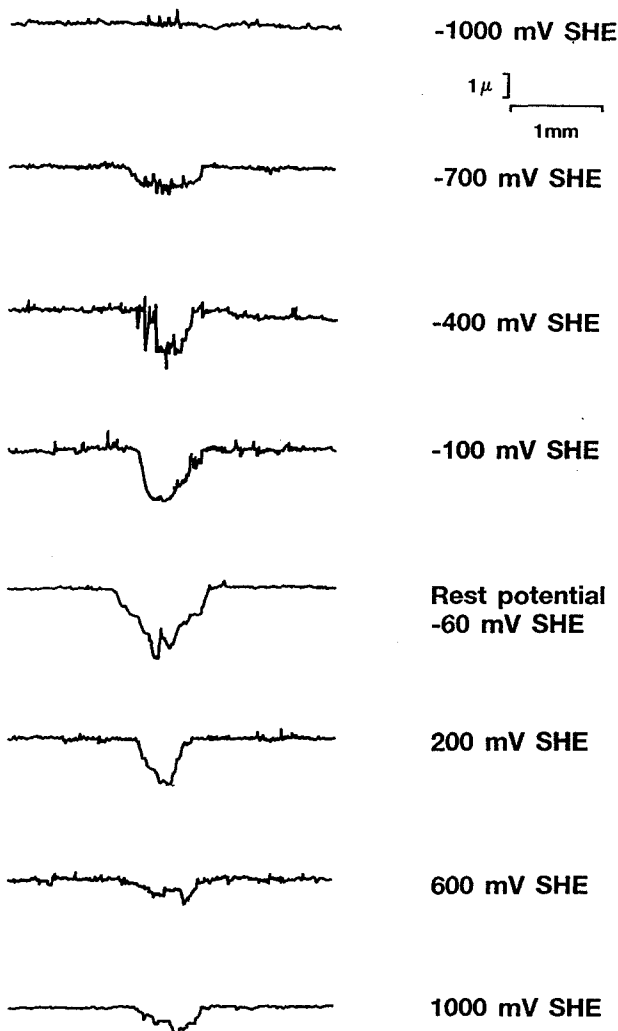

Fig. 4. Wear scar profiles produced by 50 mm radii mild steel pins on mild steel plates at a load of 10 N in a pH 9.2 solution of 1 wt % sodium octanoate.

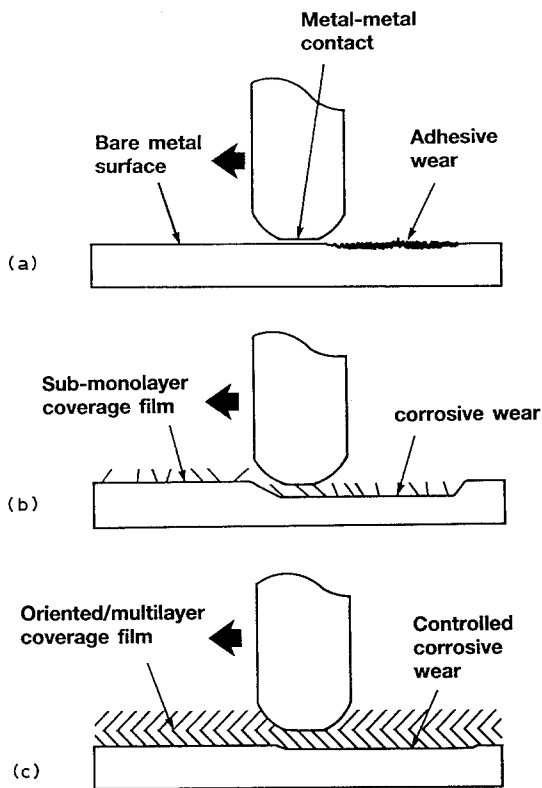

Fig. 5. Schematic illustration of three potential dependent wear modes. (a) Adhesive wear due to metal-metal contact at cathodic potentials. (b) Corrosive wear in the presence of a submonolayer octanoate film at open circuit. (c) Controlled wear in the presence of an adsorbed oriented or multilayer octanoate film at anodic potentials.

potentials (indicated by a large number of asperities within the wear scar) at, and anodic of, -100 mV vs SHE. In these low contact stress experiments, pin wear was too small to be measured.

The friction and wear response can be explained by the potential dependent formation of an adsorbed film of carboxylate anions, $\text{CH}_3(\text{CH}_2)_6\text{COO}^-$. These may be held at the surface via electrostatic interaction with the charged electrode, and/or may react with the metal

to form a layer of iron octanoate. Interfacial capacitance measurements on iron in octanoic acid [13] have established that at cathodic potentials little or no octanoate film is present on the electrode surface. The electrode coverage increases as the potential is made more anodic, coinciding with a decrease in the static coefficient of friction. At potentials anodic of about 500 mV vs SHE the capacitance measurements suggested that more than one layer of octanoate may be adsorbed. This is consistent with Yeskie and Harwell [14], who suggested that the formation of bilayered admicelles was favoured during the adsorption of ionic surfactants from aqueous solution provided the surface was away from its point of zero charge.

Therefore at cathodic potentials, where no adsorbed lubricating film is present, direct metal-metal contact occurs between pin and plate leading to high friction and adhesive wear. Changing the potential to less cathodic values drives adsorption towards monolayer coverage and friction is greatly reduced. In the absence of rubbing, the film formed also inhibits corrosion of the metal. However with rubbing the wear pin removes this protective film, allowing corrosion to occur within the wear scar. As the potential continues in the anodic direction, a point is eventually reached where a more stable film is formed. This could take the form of a 'carpet' of close packed, vertically oriented octanoate species, or a thicker, bi or multilayer film. Movement of the pin then no longer exposes fresh metal surface, and corrosive wear is dramatically reduced. Concomitant with this decrease in wear is a small drop in friction (Fig. 3), particularly in experiments performed at higher contact stresses (Figs 6 and 7). This may well correspond to multilayer formation since experiments with Langmuir-Blodgett films of carboxylic acid have shown that multilayer films have shear strengths 20% less than monolayer films [15].

Thus, the peak in wear can be explained by competition between oxidative corrosion (increasing wear), and protective film formation (inhibiting wear), as the potential is made anodic. This is schematically depicted in Fig. 5.

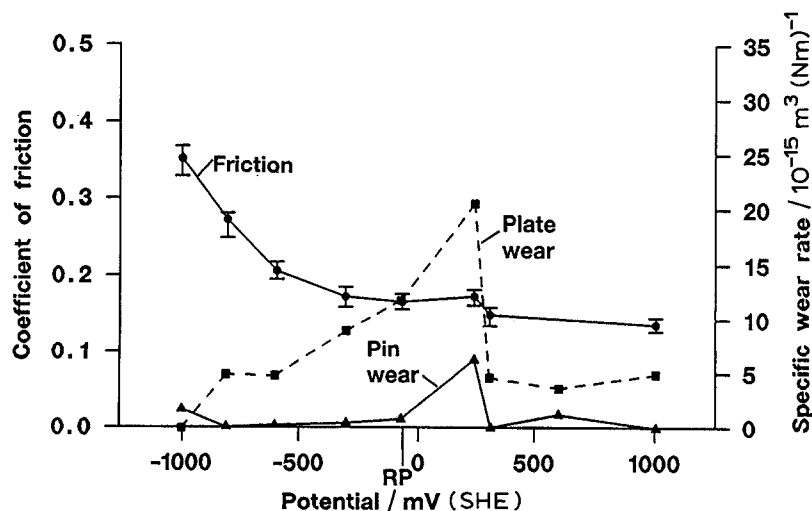

Fig. 6. Potential dependence of friction and wear for 25 mm radii mild steel pins on mild steel plates at a load of 40 N in a pH 9.2 solution of 1 wt % sodium octanoate.

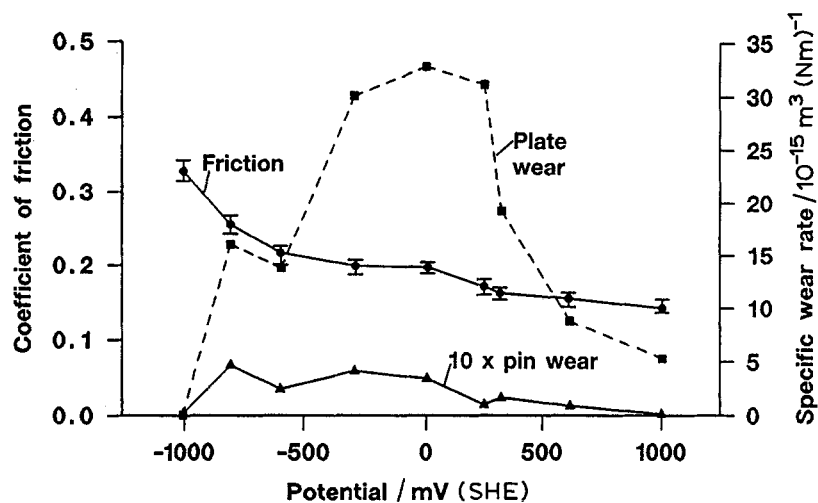

Fig. 7. Potential dependence of friction and wear for 25 mm radii high speed steel pins on mild steel plates at a load of 40 N in a pH 9.2 solution of 1 wt % sodium octanoate.

The effect of potential on friction and wear at a higher contact stress was then examined using 25 mm radii mild steel pins at a load of 40 N. Figure 6 shows that friction decreased steadily from -1000 to $+240$ mV, where it took a small downward step, perhaps corresponding to the previously discussed formation of a vertically oriented or multilayer film. Friction was lower than that obtained with 50 mm pins at 10 N (Fig. 3). Plate wear again displayed a maximum, but at a potential more anodic than before. The higher contact stresses made the pin wear rate accessible, and this showed similar trends to plate wear.

Tests were also carried out using 25 mm radii high speed steel pins at a load of 40 N and the results at nine potentials are given in Fig. 7. Friction data were almost indistinguishable from those obtained with mild steel (Fig. 6). However, plate wear rate was higher and the wear peak broader. Increased plate wear is probably due to the greater hardness and wear resistance of the pin since, with less pin wear, contact stresses are maintained at higher levels throughout the

experiment. These higher stresses may also result in the broader wear peak because the protective film would be more easily removed. The decrease in plate wear occurred at the same anodic potential as with mild steel (Fig. 6). As expected, pin wear rates were low but appeared to decrease on going from cathodic to anodic potentials.

The lubricity of the electrochemically induced film was then tested at a range of contact stresses by varying the load over the range 10 to 150 N using 25 mm radius mild steel pins. The experiments were conducted at three potentials (-1000 mV, rest potential (RP) and $+600$ mV), selected respectively to represent no film, the film thickness naturally occurring, and enhanced film formation. Coefficients of friction are shown in Fig. 8. Friction was highest at the cathodic potential, indeed tests were not carried out at loads above 80 N at this potential due to the high friction coefficients obtained. At the rest potential, after a small initial fall, the response to load was quite flat. Friction was lower during the anodic runs than at the

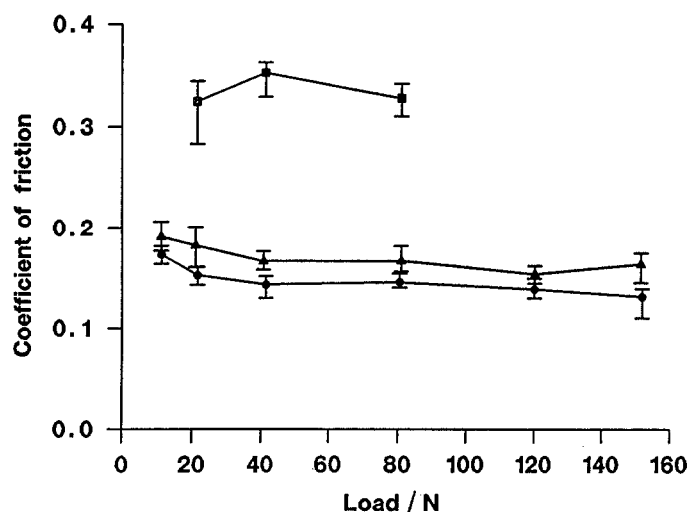

Fig. 8. Dependence of friction on load for 25 mm radii mild steel pins on mild steel plates at cathodic, rest and anodic potentials in a pH 9.2 solution of 1 wt % sodium octanoate. (■) cathodic (-1000 V), (▲) rest potential, (●) anodic ($+600$ mV).

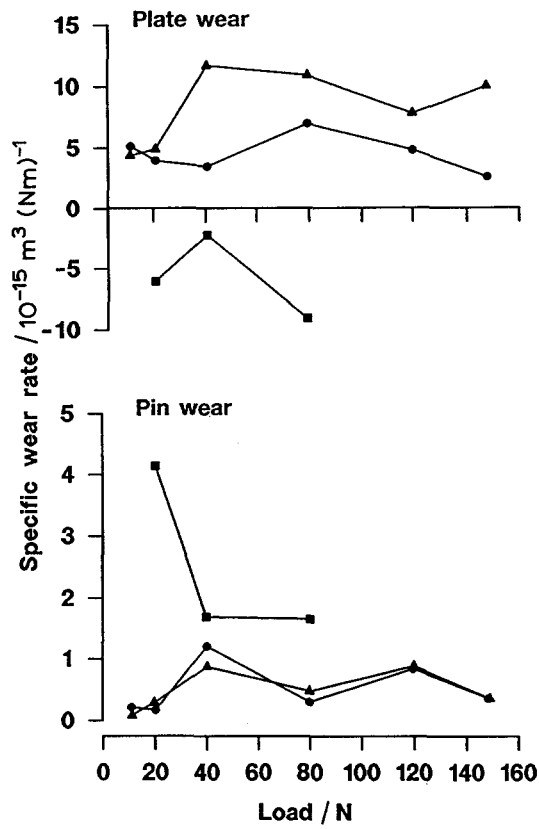

Fig. 9. Dependence of plate and pin wear on load for 25 mm radii mild steel pins on mild steel plates at cathodic, rest and anodic potentials in a pH 9.2 solution of 1 wt % sodium octanoate. (■) cathodic (-1000 V), (▲) rest potential, (●) anodic (+600 mV).

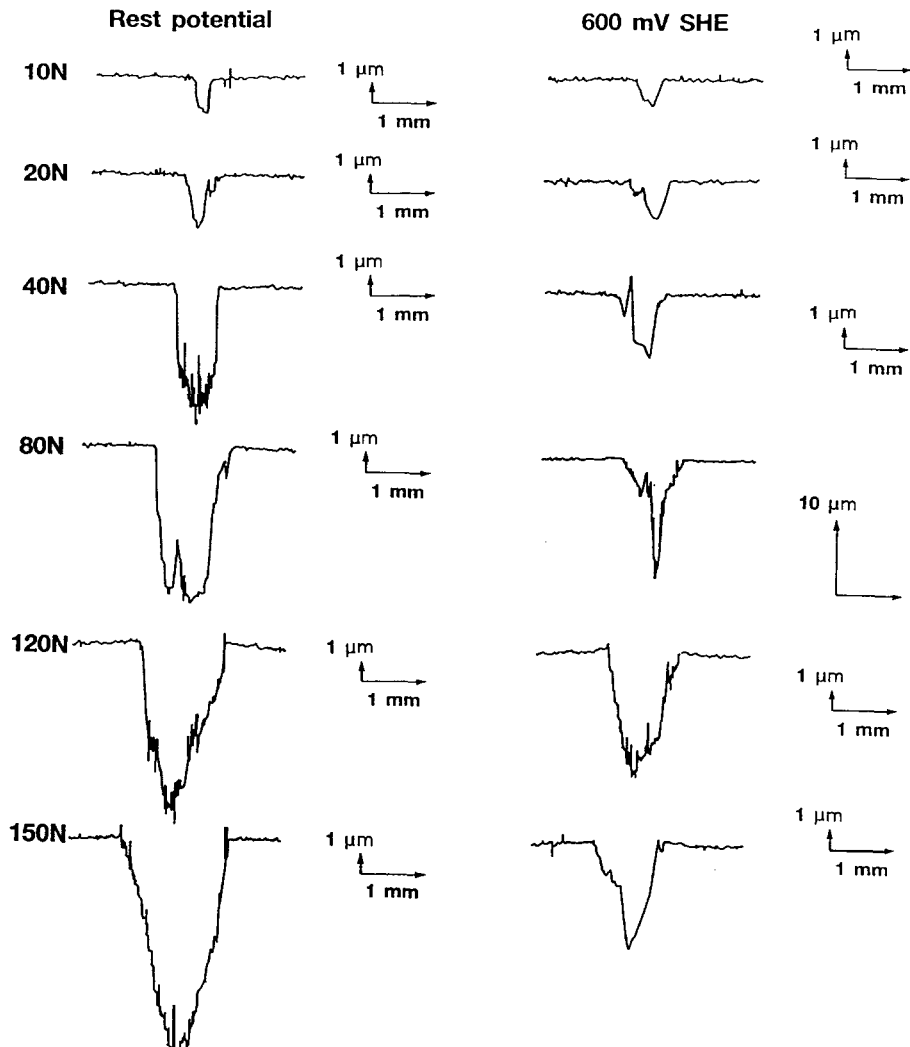

Fig. 10. Wear scar profiles produced by 25 mm radii mild steel pins on mild steel plates at both rest potential and 600 mV/SHE in a pH 9.2 solution of 1 wt % sodium octanoate.

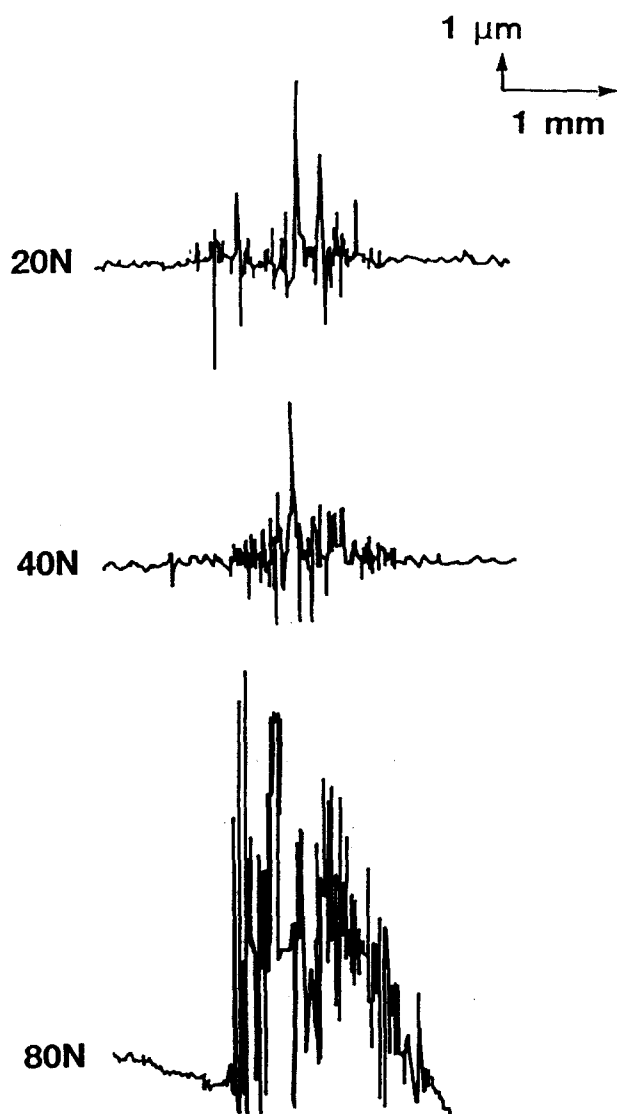

Fig. 11. Wear scar profiles produced by 25 mm radii mild steel pins on mild steel plates at -1000 mV/SHE in a pH 9.2 solution of 1 wt % sodium octanoate.

rest potential; averaged over all loads the reduction was 14%. It is evident from the friction measurements that the film retained its integrity at high contact stresses.

The response of plate wear to load is shown in Fig. 9. At loads below 20 N the wear rates for the rest potential and anodic runs were, within experimental error, equal. Above this load, wear rates at rest potential rose to about double their original value, while those for the anodic runs did not show any systematic increase. The different wear behaviour with potential was also shown in the wear scar profiles (Fig. 10). At the rest potential, a transition from light controlled wear to severe adhesive wear can be seen when the load exceeds 20 N. However, at 600 mV, adhesive wear is only evident at 120 N, with some evidence of

partial film breakdown (scratching) at 80 N. At the cathodic potential the Talysurf profiles (Fig. 11) showed that severe adhesive wear occurred, with material being deposited from the pin on to the plate.

Figure 9 also illustrates that the highest pin wear rate was observed at the cathodic potential, corresponding to metal transfer from pin to plate. No difference in pin wear rate was observed between the anodic and rest potential; this may reflect the different conditions experienced by the pin as compared to the plate, since the pin is in continuous rubbing contact and may be unable to form a lubricating film at the anodic potential.

4. Conclusions

Imposing an applied potential can produce three different friction and wear regimes for mild steel in a pH 9 solution of sodium octanoate, namely high friction/low wear, low friction/high wear, and low friction/low wear. These regimes are produced through potential dependent changes in the coverage and stability of a lubricating fatty acid film on the surface of the steel. A maximum in plate wear is produced by the competing effects of oxidative corrosion and protective film formation at anodic potentials.

Acknowledgements

Permission to publish this paper has been granted by the British Petroleum Company plc.

References

- [1] D. N. Staicopoulos, *J Electrochem Soc.* **108** (1961) 900.
- [2] A. D. Monvernay, J. E. Dubois and P. C. Lacaze, *J Electroanal Chem.* **89** (1978) 149.
- [3] A. Volkov, P. C. Lacaze and J. E. Dubois, *ibid.* **115** (1980) 279.
- [4] J. E. Dubois, A. D. Monvernay and P. C. Lacaze, *ibid.* **132** (1982) 177.
- [5] R. J. Brigham, *Corros. Sci.* **29** (8) (1989) 995.
- [6] F. H. Stott, J. E. Breakwell and R. C. Newman, *ibid.* **30** (8/9) (1990) 813.
- [7] B. R. Pearson, P. A. Brook and R. B. Waterhouse, *Tribology Int.* **21** (4) (1988) 191.
- [8] A. Iwabuchi, T. Tsukamoto, Y. Tatsuyanagi, N. Norifumi and T. Nonaka, *Wear* **156** (1992) 301.
- [9] A. Iwabuchi, T. Sasaki, K. Hori and Y. Tatsuyanagi, *JSME Int. J.* **35** (1) (1992) 117.
- [10] M. F. Lizandier, E. Lanza, A. Seboun, A. Giroud and P. Guiraldenq, *Wear* **153** (1992) 387.
- [11] G. H. Kelsall, H. A. Spikes and Y. Y. Zhu, *J. Chem. Soc. Faraday Trans.*, **89**(2) (1993) 267.
- [12] Y. Y. Zhu, G. H. Kelsall and H. A. Spikes, *Amer. Soc. Trib. Lub. Eng.*, to be published.
- [13] N. P. Brandon, N. Bonanos, P. O. Fogarty and M. N. Mahmood, *J. Electrochem Soc.*, **139**(12) (1992) 3489.
- [14] M. A. Yeskie and J. H. Harwell, *J. Phys. Chem.* **92** (1988) 2346.
- [15] B. J. Briscoe and D. C. B. Evans, *Proc. Roy. Soc. Lond.* **A380** (1982) 389.